

ncp NAIROBI CITY PLAYERS

Presents

at the KENYA NATIONAL THEATRE

Aladdin

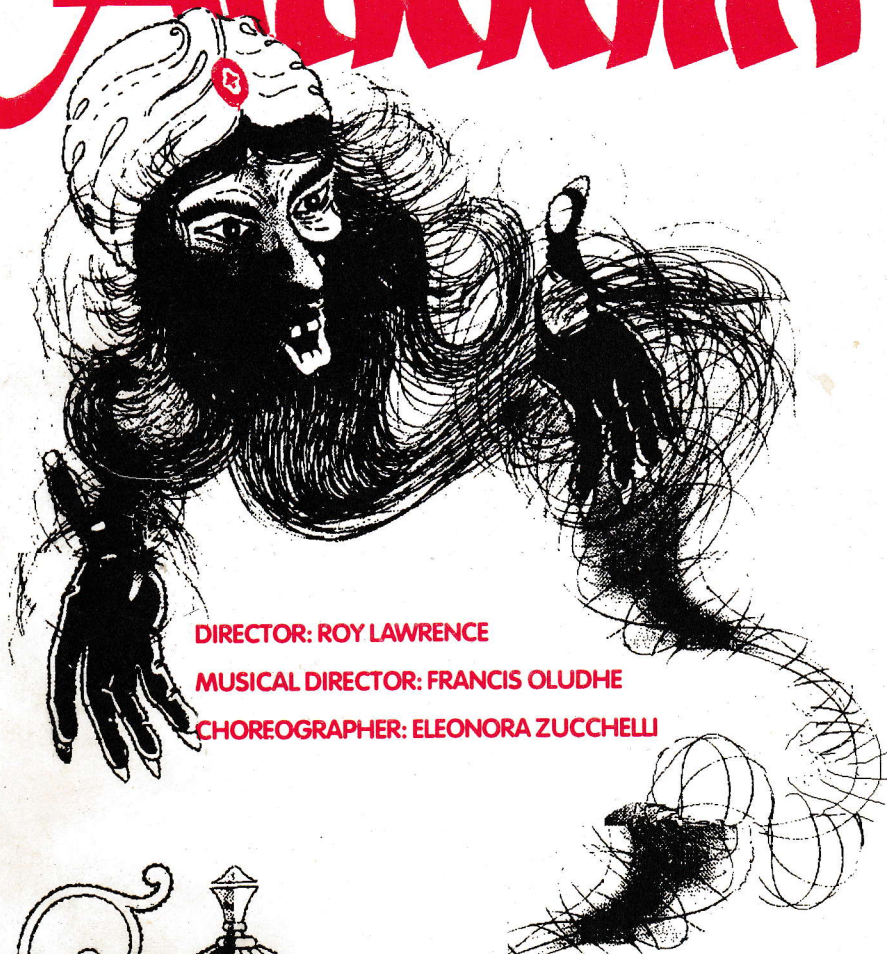

DIRECTOR: ROY LAWRENCE

MUSICAL DIRECTOR: FRANCIS OLUDHE

CHOREOGRAPHER: ELEONORA ZUCHELLI

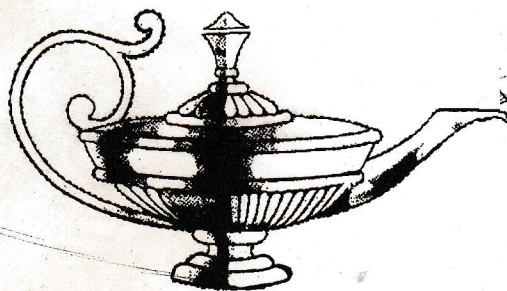

Swissair 
Time is everything

YOU'RE **IN CONTROL**

WITH A **NISSAN PATROL**

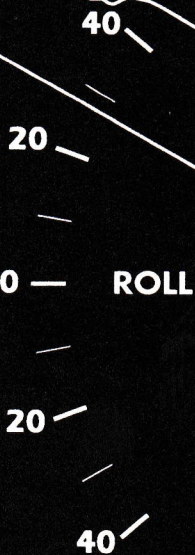
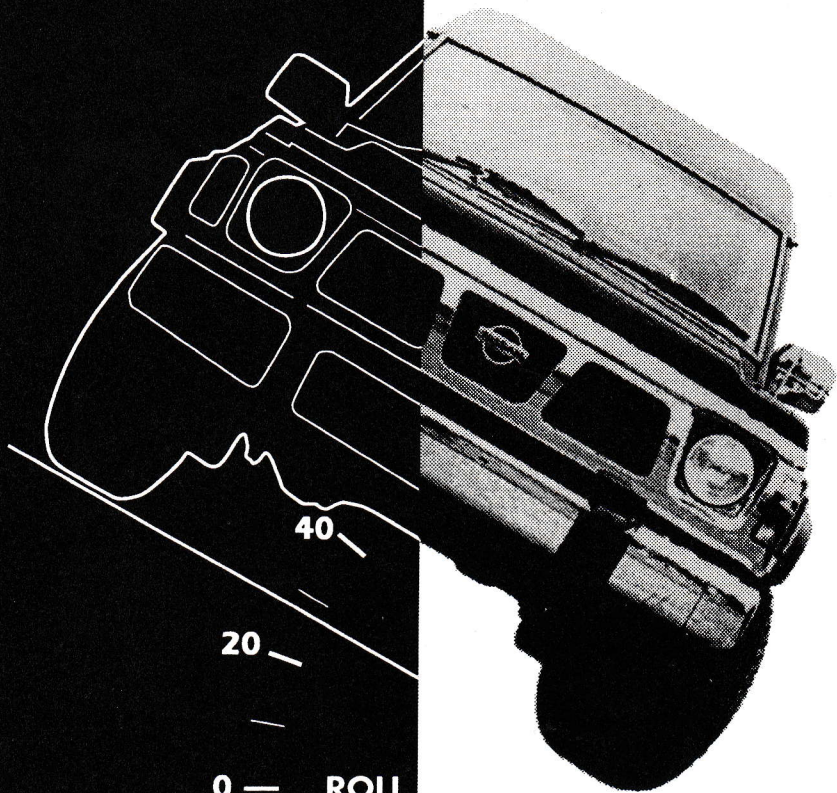

Whatever you're inclined to think about four-wheel drives, the Nissan Patrol will change your point of view. Inside the beautifully equipped interior, you'll discover a whole new concept of four-wheel drive luxury. Step inside the ergonomically-designed cockpit, and you'll notice that every piece of instrumentation is designed to help you take command. A gutsy, power-packed engine and world-proven four-wheel drive give you the extra power and dependability you need when the going gets tough. And the light-touch power steering makes

for easier, surer handling. So whether you want practicality or style, travelling in the Nissan Patrol is an experience of uncompromising comfort and luxury. While prices start from shs 3,422,000 V.A.T paid, D.T. Dobie can also supply duty-free vehicles. In addition, customised options are available. Call on your nearest D.T. Dobie showroom today and see one. It will change your point of view about four-wheel drives!



D.T. Dobie
APPRECIATES YOUR CAR

D.T. DOBIE & COMPANY (KENYA) LIMITED, PO BOX 30140, NAIROBI, KENYA. TELEPHONE 331505/542240
TELEPHONE 011-316735/037-211775



FRANCES CATTERMOLLE
Chairman

FORWARD

Pantomime is here again! As you watch our latest Grand Traditional Pantomime "Aladdin", we can be sure that pantomimes are being staged at this time throughout the world where English speaking people are living. There are no fewer than 24 Pantomimes being staged in London and leading repertory theatres around Britain. Audience participation is an essential ingredient, booing and hissing the villain whenever he appears, cheering the good character when he succeeds in thwarting his wickedness, warning the characters on stage when in danger - and the song sheet that everyone in the audience sings and dances the movements. Good Pantomime has everything!

What better entertainment can there be for all the family for the Christmas period than this idiotic, exotic and irrational display which we call pantomime. Certainly Nairobi residents of all races have made it a firm favourite for their Christmas treat for their children and participate in increasing numbers for each of our panto productions. Nairobi City Players, and certainly everybody on stage in this show, love pantomime and join with essayist John Leigh who believed that:-

"Not to like pantomime is not to like animal spirits; it is not to like motion; not to like love; not to like a jest upon dullness and formality not to sympathise with one's children; not to remember we have been children ourselves"

I wish you all a Merry Christmas and a Happy New Year.

NAIROBI CITY PLAYERS
MANAGEMENT COMMITTEE



FRANCES
CATTERMOLE
Chairman

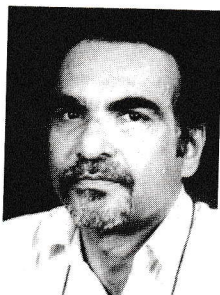

RAJ THAKAR
Business Manager

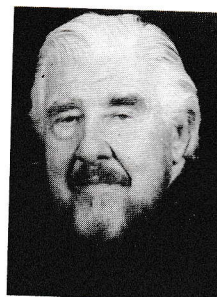

RURIK
RONSKY
Member



JENNY
DUNNET
Member

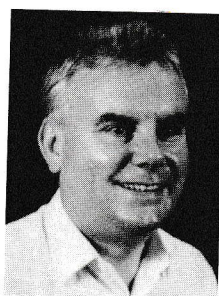

GERRY
McCRUDDEN
Member

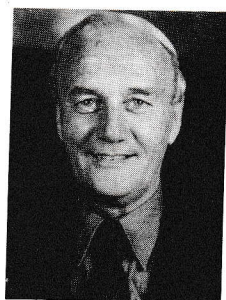

ROY
LAWRENCE
Member



JACQUI MASON
Member



LESLEY
MULLAN
Member

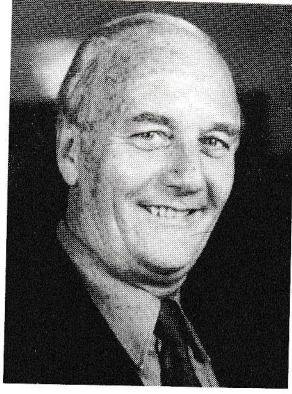

ROY LAWRENCE

FROM THE DIRECTOR'S DESK

The last "panto" I directed in Nairobi, several years ago, was "Jack and the Beanstalk" for Theatre Group at St. Mary's School. This year, Nairobi City Players produce "Aladdin and his wonderful Lamp" based very loosely on one of the fabulous "Thousand and One Arabian Tales", the source of many modern pantomimes. The action begins in Baghdad where Scheherezade, favourite of the Sultan, tells the story of a wonderful Lamp hidden in a cave in far off China which can only be recovered by one Aladdin, a young lad who lives with his widowed mother in Perkin. Upon Hearing of this, Abanazar, evil vizier to the Sultan, insists that he be guided by Scheherezade, whom he entraps as slave of his magic ring, to find this Aladdin and to get the lamp for himself. Aladdin spends most of his time stealing apples from the Emperor's orchard. One day he bumps into and falls in love with the Princess So Shy. Abanazar finds Aladdin and persuades him to go to the Cave of Doom. Aladdin finds the lamp and the Genie who makes Aladdin a rich Prince. But Abanazar by deceit obtains the lamp and takes So Shy and all Aladdin's new found wealth back to Baghdad. Aladdin, with the help of his mother, Widow Twankey, her assistant, Wishy Washy, and Scheherezade rescues So Shy and the lamp, returns to Perkin to live happily ever after!

DIRECTOR A PROFILE

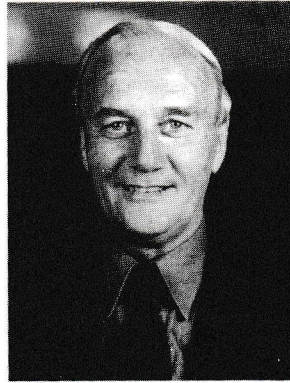

ROY LAWRENCE

From an early age in Manchester, England, Roy took an interest in Theatre assisting back-stage and playing "bit" parts whenever possible. He came to East Africa as a young man where he worked in Kampala, Dar-es-Salaam and finally Nairobi. He has produced, choreographed and taken part in several successful productions including "Sinbad the Sailor", "Kiss Me Kate", "The Rivals", "Aladdin", "Guys and Dolls", "A Funny Thing ...", "Wait Until Dark" and "Man For All Seasons". Last year he played the part of "Fanny" the better looking ugly sister, in the excellent production of "Cinderella" directed by Larry Oaks, whom Roy would like this production dedicated!

CHOREOGRAPHER



ELEONORA ZUCHELLI

Born in the northern part of Italy, Elle started dancing at the tender age of four and continued to practice as she travelled around the world with her parents. Elle trained for jazz, ballroom and ballet dancing as well as mime. She is now a qualified health trainer. Elle came to Kenya ten years ago and has worked in several different productions before being a part of N.C.P three years ago. She has a beautiful seven month old baby - Max, who takes up all her time when she is not working for NCP or Capolinea, the family business.

MUSICAL DIRECTOR



FRANCIS OLUDHE

Francis is currently the Head of Music at Kenton College, and has been teaching music for 6 years. This is the first time for him to direct, and was rather nervous, at first, but is now enjoying it. He feels he has been lucky with all the help and cooperation he has received from the director and all the band members. He has taken part in many productions as rehearsal pianist, so this is a big leap forward!

THE CAST

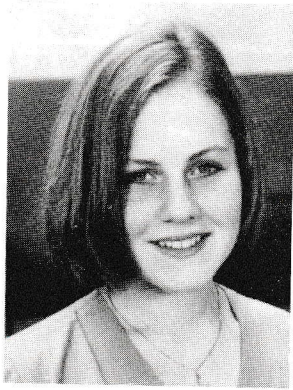

GEORGIANNA HARTLEY - Aladdin

Aladdin is Georgianna's third NCP production - she has played as "Anybody's", in "West Side Story" and was a principal dancer in NCP's multi-media LifeGame: "Truth & Phantasy in Freeflow".

Resident in Kenya with her parents, brother and sister since 1985 and presently completing A level studies at St. Austin's Academy, Georgianna has taken full advantage of the opportunities afforded her in theatre and dance in Nairobi. In addition to her experiences with Nairobi City Players and in several variety/dance productions, she also portrayed "Little Buttercup" in Braeburn Player's staging of Gilbert & Sullivan's "HMS Pinafore".

While she enjoys several aspects of performance-acting, singing and dancing - it is dance that is Georgianna's primary interest. A serious student of ballet for thirteen years, she will in September 1995 begin Degree studies in Ballet and Modern Dance at university in her home state of Texas in the U.S.A.

THE CAST - Continued



NICOLAS OLE MOIPEI - Sultan

Born in Kajiado in 1961 Nicholas graduated from Kenyatta University where he studied Music in 1991. He has taught music in both high school and college levels. He is currently teaching music at Loreto Convent-Msongari High School.

MARK INGALL - Widow Twankey

Mark is Head of Sciences at Kenton College here in Nairobi. He first took to the stage at this theatre just over two years ago when he was 'plucked' from the chorus line to be "Riff" in NCP's production of "West Side Story". He has also appeared here for the NCP as the "King of the Rats" in "Dick Whittington", "Annie Hardup", one of Cinderella's ugly sisters in "Cinderella" and "Gerry" in "Dancing at Lughnasa". Mark has also had Major roles at Phoenix Theatre, with the United Freelance Artistes at the French Cultural Centre and has also appeared in the Norfolk Players after dinner cabarets as well as filming a supporting role in the feature film "The Ascent" filmed earlier this year on Mt. Kenya.

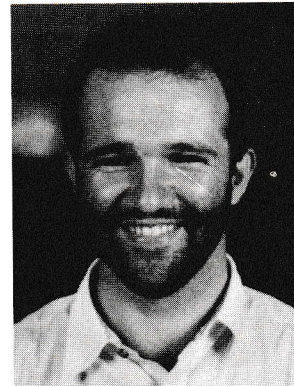

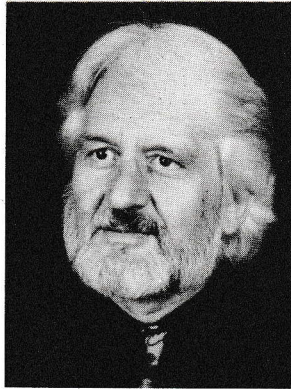

Dr. ERNST TENAMBERGEN
Abanazar

Ernst says he was born a couple of years ago in 1954 and is now part of a rather international family with three children - Somali - German and Ethiopian elements. A physician by profession, Ernst did quite a bit of emergency surgery in trouble spots around the world before specializing in internal medicine. He has been teaching at the University of Nairobi for the past five years. He loves music especially jazz. Since he managed to escape from learning anything by heart in school and sings mostly in the bathtub, he feels quite challenged by being thrown into the cast and is highly enjoying it.

JACQUI MASON - Wishy

Jacqui made her "stage" debut at the age of three, singing and dancing on a table top in a pub - The Winning Post - in Twickenham, England. She sang "You Are My Sunshine" to British and American servicemen home on leave from fighting in Europe. From that day music and drama have been part of her life. She has appeared in most American musicals, in cabaret, in Old Tyme Music Hall, in straight plays, in pantomime and sang tenor in her local choir for 26 years. She took a break from theatre in the sixties to have her five children but resumed when the oldest boy joined the school choir. This school choir became famous for its Christmas television broadcast of Carols on Christmas eve. At one time Jacqui and her five children were all part of that choir as they were of the church choir. She met her husband, Robin, through music and he and his daughter were part of both church and school choirs. In Kenya she is again involved with music being Chairman of the Nairobi Music Society and a committee member of Nairobi City Players. She says whether performing, doing administration or behind the scenes, it doesn't matter, she still gets that theatrical "buzz" on opening night.



THE CAST - Continued

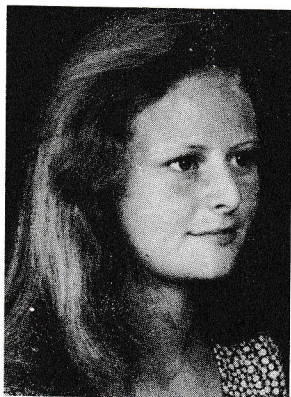

JEANETTE ELSWORTH -
Princess So Shy

Jeanette was born in England in a town called Plumstead but came to Kenya when she was four and has lived here ever since. She has had singing and dancing parts in school plays and has danced a number of times for the intercontinental Hotel. However, apart from dancing parts in "Cinderella" at the National Theatre a long, long time ago, and "Asterix and The Big Fight", at Braeburn, this is her first major production.

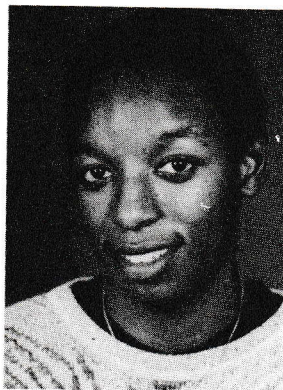

TONNY KIMANI - Genie

The spirit of theatre never fails to excite Tunny even though he is no newcomer to theatre, "I can't help it!" he wails.

Tunny works as a producer in a media company in Nairobi. He is 19 years old. Tunny hopes to eventually make it to Broadway, "just watch me!" he boasts.

THE CAST - Continued

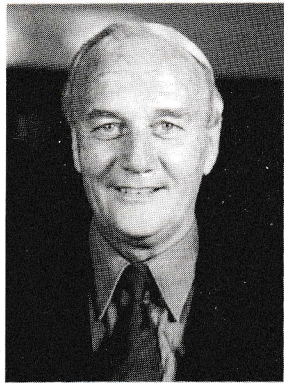

ROY LAWRENCE - Emperor

Though not "born in a trunk" he is the youngest son of one of the original "Tiller Girls" (a famous dancing troupe). From an early age in Manchester took an interest in theatre, assisting backstage and playing "bit" parts whenever possible. Came to East Africa as a young man and worked in Kampala, Dar-es-Salaam and Nairobi where he produced and played in several successful shows. Last appeared as "Fanny" in "Cinderella" in 1993.

MARY ANNE CORNU - Scheherezade

Mary teaches English at the French School in Nairobi. She has performed in "Dick Whittington" and "West Side Story" for NCP and five other plays including four leading roles at Phoenix.

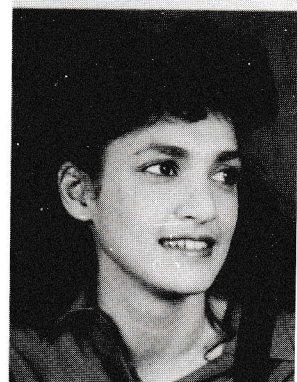

ALAD

DIRECTED BY: RO

CHOREOGRAPHER: ELE

MUSICAL DIRECTOR: I

MUSICIANS

PIANO	-	FRANCIS OLUDHE
KEYBOARD	-	GEOFFREY NJOGU
FLUTE/TENOR SAXOPHONE	-	MURIUKI MUGAMBI
CLARINET	-	NJANE MUGAMBI
BASS GUITAR	-	ALVAREZ AMWAYI
LEAD GUITAR	-	SHADI OSMAN



STAGE DIRECTOR
FRANCES CATTERMOLÉ

SCENES ACT ONE

Scene	1	PASSAGE TO THE SULTAN'S CHAMBER - BAGHDAD
Scene	2	COURTYARD OF THE EMPEROR'S PALACE IN PERKIN
Scene	3	STREET OF A THOUSAND BULLOCKS
Scene	4	WIDOW TWANKEY'S LAUNDRY
Scene	5	OUTSIDE THE CAVE OF DOOM
Scene	6	THE CAVE OF DOOM

ACT TWO

Scene	1	WIDOW TWANKEY'S LAUNDRY
Scene	2	STREET OF A THOUSAND BULLOCKS
Scene	3	GARDEN OF THE EMPEROR'S PALACE
Scene	4a	PASSAGE OF TIME
Scene	4b	OUTSIDE THE SULTAN'S PALACE - BAGHDAD
Scene	5	THE THRONE ROOM OF THE SULTAN'S PALACE
Scene	6	THE STREET
Scene	7	THE WEDDING OF ALADDIN AND PRINCESS SO SHY

MUSICAL ACT

NOT SINCE NINEVAH	SHEHERE
AQUARIUS	WISHY an
CHINA TOWN	CITIZENS
A WHOLE NEW WORLD	ALADDIN,
IN THE SUMMERTIME	WISHY, PI
ABRACADABRA	WIDOW T
THE OLIVE TREE	ABANAZA
CALL ME AL	GENIE, AL
THE DANCE OF JEWELS	JEWEL QI
FIRE DANCE	JEWEL QI

ACT

DANCING IN THE STREET	WIDOW T
CHOP SUEY	WISHY G
NOTHING GONNA STOP ME NOW	ABANAZA
WHEN I'M SIXTY-FOUR	WIDOW T
I ENJOY BEING A GIRL	PRINCESS
I AM WHAT I AM	KUNG FU
PASSAGE OF TIME	SPIRITS
UPSIDE DOWN	WISHY, A
SHADDUP YOU FACE/ SONG SHEET	ABANAZA
ITS THE DAY	FULL GOI

ALADDIN

ROY LAWRENCE
ELEONORA ZUCCHELLI
DR. FRANCIS OLUDHE

COSTUMES

LESLEY MULLAN, JACQUI MASON, PATTI RANSOM
JANE BARNARD, JANE CORFIELD, PATTI LIMITED



COSTUME DESIGNER
LESLEY MULLAN

MUSICAL NUMBERS ACT ONE

SCHEHEREZADE, SULTAN, ABANAZAR and CITIZENS
WISHY and CITIZENS
CITIZENS
ALADDIN, PRINCESS SO SHY and CITIZENS
WISHY, PING, PONG and CITIZENS
WIDOW TWANKEY, ALADDIN, WISHY and CITIZENS
ABANAZAR
GENIE, ALADDIN and SCHEHEREZADE
JEWEL QUEEN, PRINCESSES and JEWELS
JEWEL QUEEN AND PRINCESSES

ACT TWO

WIDOW TWANKEY, WISHY, PING, PONG and CITIZENS
WISHY GENIE, ALADDIN and CITIZENS
ABANAZAR, PING, PONG and CITIZENS
WIDOW TWANKEY and EMPEROR
PRINCESS SO SHY, LOO and LANG
KUNG FU, EMPEROR, WIDOW TWANKEY, ALADDIN, LOO and LANG
PARTS
WISHY, ALADDIN, PING and PONG
ABANAZAR, PING, PONG, GENIE and YOURSELVES
FULL COMPANY

THE CAST In order of appearance

SCHEHEREZADE	MARY ANNE CORNU
SULTAN	NICHOLAS OLE MOPEI
ABANAZAR	ERNST TENAMBERGEN
PING	JACKIE HOLT
PONG	ALESSANDRO ZUCCHELLI
LOO	CORRINE DOUGLAS
LANG	KIRUU MBUGUSS
PRINCESS SO SHY	JEANETTE ELSWORTH
ALADDIN	GEORGIANNA HARTLEY
YUM-YUM	CIERA MULLAN
YANG	ANDREW KIRAGU
YING	CHARLES OTIENC
WIDOW TWANKEY	MARK INGALL
KUNG FU	GEOFFREY NJOGU
WISHY	JACQUI MASON
GENIE	TONNY KIMANI
EMPEROR	ROY LAWRENCE

THE CAST - Continued

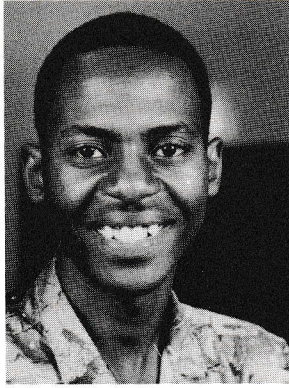

GEOFFREY NJOGU - Kung Fu

Geoff was born in Kenya and studied at Starehe Boys Centre where he acted in three musical productions - "Tom Sawyer", "The Hobbit" and "Tin Pan Ali". He has also been in the pit band for the three NCP productions "West Side Story", "Ali Baba" and "Dick Whittington" but this is his NCP stage debut.

CIERA MULLAN -
Yum-Yum (the Monkey)

She is a nine year old student at Nairobi's French School. She enjoys dancing and gymnastics and has appeared in ballet shows at the French Cultural Centre and Braeburn Theatre. Ciera first appeared on stage for NCP in the children's chorus of "Cinderella" in 1993.

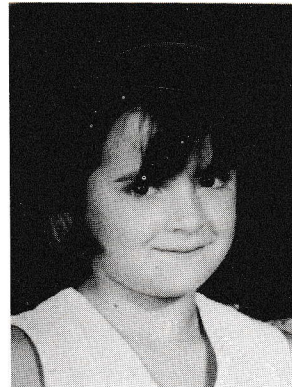

THE CAST - Continued



JACKIE HOLT - Ping

Born in Kisumu more than a few years ago, Jackie's first real introduction to the world of theatre came at a tender age of 12 when she played one of the Von Trapp children in N.C.P's productions of the "Sound of Music". From there on it was a matter of 'once bitten always smitten'. Jackie has tried over the years to do at least one show per annum, preferring the Christmas pantomime for its fun filled antics. She says it is a wonderful way to lose a few pounds before thoroughly indulging oneself over the festive season. Apart from NCP, Jackie has also worked with Phoenix Players and was a member of the Theatre group in earlier days.

ALESSANDRO ZUCHELLI - Pong

Alessandro, seventeen year old student at the Italian School Nairobi and makes his stage debut in this production. NCP are confident that we shall be seeing more of him in future productions.

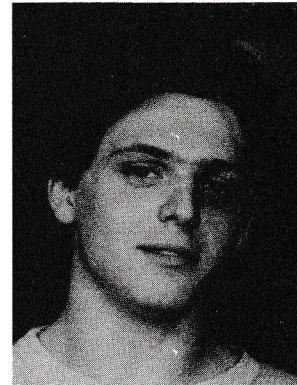

THE CAST - Continued

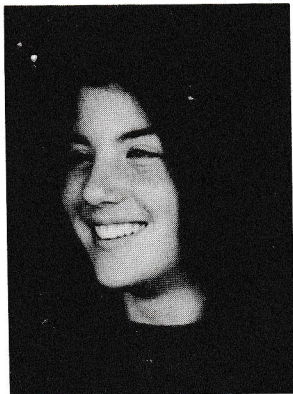

CORRINE DOUGLAS - Loo

Born in London 14 years ago, Corrine has lived in London, Bahrain, Korea, the United States and Kenya. She has taken six years of dancing, four years of vocal and one year of dancing. She performed in Dallas Nutcracker for three years, was in sing and dance troupe called "Kids to Go", played the "Cat" in ISK's production of "Animal Farm" and a schoolgirl in "Share and Share Alike". She plays piano, clarinet and saxophone.

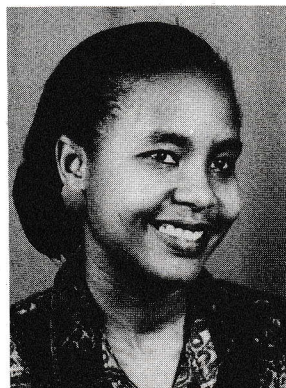

KIRUU MBUGUSS - Lang

Kiruu last appeared on stage for NCP in their production of "Annie" in 1986 as one of the orphans, so we welcome her back after a long absence.

THE CAST - Continued

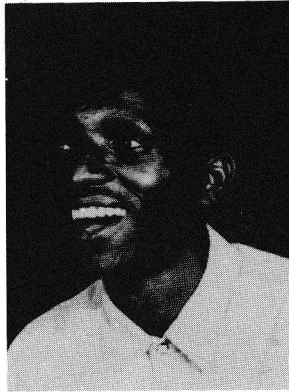

CHARLES 'Opotis' OTIENO - Ying

This is his third major production with NCP. He hopes you enjoy this traditional end year panto and wishes you a Merry Christmas and a Happy New Year.

ANDREW KIRAGU - Yang

This is his third production on stage with NCP and says its quite a production to be in. He has worked with different theatre groups in Nairobi and Mombasa. He likes writing and has just finished his second script entitled "Testimony", which is a musical play which he plans to stage at Buru Buru Christian Centre in the coming year.

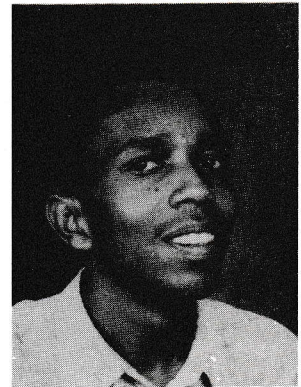

CITIZENS



BACK ROW - LEFT TO RIGHT

CHIRAG SHETH, JOHN MUINDI, BRUCE CATTERMOLE, NICHOLAS OLE MOIPEI, JOHN ODOR, AMAZING GRACE KIBARABARA.

FRONT ROW - LEFT TO RIGHT

CATHERINE MAINGI, AGA BURHABWA, AFRAH TENAMBERGEN, LOIS WAMAITHA, MEYLIN ZINK.

CHILDREN & JEWELS



BACK ROW - LEFT TO RIGHT

BYRONNY NICKLIN, GEORGIA MULLAN, JESSICA CORFIELD, ALEXANDRA STENNING, REENA SHAH.

FRONT ROW - LEFT TO RIGHT

AKI ASAKA, MAYANKH UMAMAHESWAR, KARUNGARI WAMBUGU, COURTNEY JAMES, REHKA PAUNRANA, DEEPAK SHETH, YUKI ASAKA.

JEWEL QUEEN & PRINCESSES



SEATED - AFRAH TENAMBERGEN

LEFT TO RIGHT - GEORGIA MULLAN, AKI ASAKA, YUKI ASAKA.

THE PRODUCTION TEAM

Stage Director	FRANCES CATTERMOLÉ
Stage Managers	ROB DUGAND, SASHA RONSKY
Stage Crew	EDDIE ONGWAE, JIM WERE, LAZARUS TSUMU, GEORGE ASAVA, JOSPHAT WAITHAKA, JOHN MWENJA
Scenery Flying Team	DANIEL MBUGUA, DANIEL NJOROGÉ, JOSPHAT WAITHAKA
Lighting	JOHN FREEMAN, JASON MWAI
Follow Spot Operators	INGRID DUGAND, DEREK BANGA
Publicity & Public Relations	JENNY DUNNET, FRANÇES CATTERMOLÉ
Properties	JENNY DUNNET
Set Construction	DANIEL MBUGUA, JOHN MWENJA, DANIEL NJOROGÉ, JOSPHAT WAITHAKA
Set Designer	CHRIS MECK
Scenic Artist	CHRIS MECK
Painters	DANIEL MBUGUA, JOSPHAT WAITHAKA, BRUCE CATTERMOLÉ
Sound	ALTAF DADANI, JOHN FREEMAN, EDDIE ONGWAE
Costume Designer	LESLEY MULLAN,
Costume Team	LESLEY MULLAN, JACQUI MASON, PATTI RANSOM, JANE BARNARD, JANE CORFIELD, PATTI LTD.
Front of House	JOAN GREENE
Programme	RAJ THAKAR

NAIROBI CITY PLAYERS
PREVIOUS PRODUCTIONS

1956	"The Love of Four Colonels"	1966	"The Wizard of Oz"
1957	"The Man Who Came to Dinner"	1966	"A View From the Bridge"
	"Ring Round The Moon"		"The Man Who Came to Dinner"
	"Payment Deferred"	1967	"Twelve Angry Men"
1958	"Romanoff & Juliet"		A Double Bill of -
	"Two Gentlemen of Soho"		"Lunch Hour"
	(Winning entry Kenya Drama Festival, 1958)		"Our Way Pendulum"
	"Carrington V.C."	1968	"The Sound of Music"
	"Will Any Gentleman"		"A Streetcar Named Desire"
1959	"Rope"		"Guys and Dolls"
	"You Can't Take It With You"	1969	"My Fair Lady"
	"The Paragon"		"The Affair"
1960	"The Diary of Anne Frank"		"How to Succeed in Business Withou Really Trying"
	"Six Characters In Search of An Author"		"After the Fall"
	"A Farrago" Comprising		"Kiss Me Kate"
	"The Proposal"	1970	"The Magistrate"
	"Uneasy Lies the Head"...		A Double Bill of -
	"Red Peppers"		"The Dock Brief"
1961	"The King and I"		"The Real Inspector Hound"
	"The Caine Mutiny Court Martial"	1971	"The Lion and The Jewel"
	"The House by the Lake"		"The Pyjama Game"
	"The Bespoke Overcoat"		"Hadrian VII"
	(Winning entry Kenya Drama Festival, 1961)		"Fiddler on the Roof"
	"The Hole"		"Kismet"
	(Drama Festival entry, 1961)	1972	"Under Milk Wood"
1962	"Caesar & Cleopatra"		"Salad Days"
	"The Long and the Short and the Tall"		"Saint Joan"
	"Men Without Shadows"	1973	"Hello, Dolly!"
	(Placed Third Winning entry Kenya Drama Festival, 1962)		"Conduct Unbecoming"
	"No Fixed Abode"		"Man of La Mancha"
	(Drama Festival entry, 1962)	1974	"A Voyage Round My Father"
1963	"See How They Run"		"Minstrels 1974"
	"Annie Get Your Gun"		"Everthing in the Garden"
	"Irma La Douce"		"Godspell"
	Excerpts from "St. Joan"		"The Rainmaker"
	(Placed Second Winning entry Kenya Drama Festival, 1963)	1975	"Oliver"
	"The Resounding Tinkle"		"Minstrels 1975"
	(Drama Festival entry, 1963)		"The Masters"
1964	"South Pacific"		"Genesis"
	"Rose"	1976	"An Inspector Calls"
	"The Valiant"		"Another Opening"
	(Winning entry Kenya Drama Festival, 1964)		"Hostile Witness"
	"The Scar"		"Cabaret"
	(Placed Third Winning entry Kenya Drama Festival, 1964 and also Best Original Play)	1977	"A Funny Thing Happened on the Way to the Forum"
	"Oklahoma"		A "Trio" season of productions including -
1965	"The Country Wife"		"The Man in the Glass Booth"
	"The Duchess of Malfi"		"The Fantasticks"
	(Placed Joint Third Winning entry Kenya Drama Festival, 1965)	1978	"The Desperate Hours"
			"The Merry Widow"
			"The King and I"
			"The Minstrels 1978"
			"The Barber of Seville"

NAIROBI CITY PLAYERS
PREVIOUS PRODUCTIONS - Continued

- "Oklahoma!"
1979 "The Pirates of Penzance"
"Guys and Dolls"
1980 "Side by Side by Sondheim"
"H.M.S. Pinafore"
"Crown Matrimonial"
"Toad of Toad Hall"
1981 "The Lady of the Camellias"
"Savoy Knights"
1982 "The Fantasticks"
"Canterbury Tales"
1983 "Happy as a Sandbag"
1984 "The Gondoliers"
(with Nairobi Music Society)
"Cinderella"
1985 "Aladdin"
1986 "Annie"
"Jack and the Beanstalk"
1987 "Old Time Music Hall"
"The Business of Murder"
"Mother Goose"
1988 "How to Succeed in Business Without Really Trying"
1989 "Godspell"
"Twelve Angry Men"
"Robinson Crusoe"
1990 "Stepping Out"
"Sleeping Beauty"
1991 "Fiddler on the Roof"
"Ali Baba and the Forty Thieves"
1992 "Habeas Corpus"
"West Side Story"
"Dick Whittington"
1993 "Cabaret Magic"
"Cinderella"
1994 "Dancing at Lughnasa"
"Lifegame '94"
-

NAIROBI
CITY
PLAYERS
SHALL
CONTINUE
TO STAGE
SIMILAR
PRODUCTIONS
IN THE
FUTURE

ACKNOWLEDGEMENTS

KENTON COLLEGE for rehearsal facilities

GREENGATES KINDERGARTEN for rehearsal
facilities

ADVERTISERS

TO ALL THOSE PEOPLE AND ORGANIZATIONS
who have given assistance after this Programme went to
press

The Nairobi City Players
wish you all
A Merry Christmas
and
A Happy New Year

Enjoy the Show

NEW! LIVER PATE NOW AVAILABLE IN 125g PACKS



Now you can enjoy our delicious Liver Pate in handy 125g packs. It's ready to eat, and simply tastes great on toast or in sandwiches.

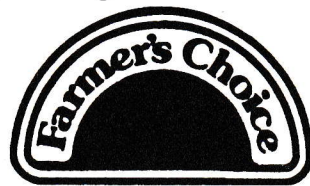

Delicatessen

Available from all leading Butcheries and Supermarkets.

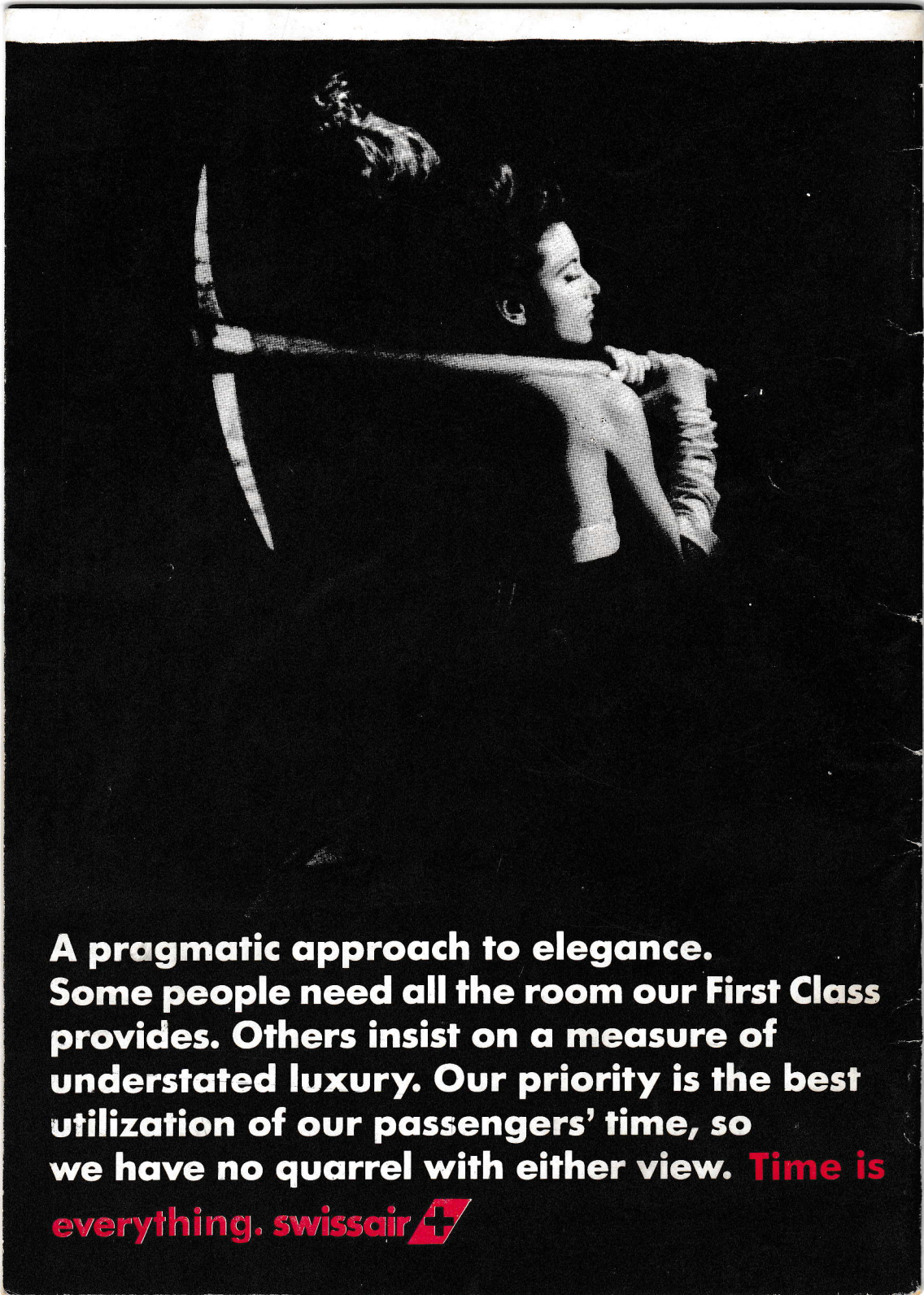

**A pragmatic approach to elegance.
Some people need all the room our First Class
provides. Others insist on a measure of
understated luxury. Our priority is the best
utilization of our passengers' time, so
we have no quarrel with either view. **Time is
everything. swissair** **